

DATA SHEET

Revision: 1.0

Release date: 10/10/2016

AG1280

Low power and low cost CPLD

General Description

AG1280 family provides low cost, ultra-low power CPLDs, with density is 1280 Look-Up Tables(LUTs). The devices feature Embedded Block Memory (EBR), Distributed RAM, and Phase Locked Loops (PLLs). The devices are designed for ultra low power and cost while providing programmable solutions for a wide range of applications, especially in consumer and mobile device products.

Features

- Low power and low cost CPLD.
 - Flexible logic architecture based on LUT.
 - Ultra-low power, as low as 60 μ A standby typical Icc (1.2V Vcc).
 - Small footprint package for consumer and mobile application.
 - Provides PLL per device provide clock multiplication and phase shifting
 - 3.3-V, 2.5-V, 1.8-V, 1.5-V LVCMOS and LVTTL standards
 - Flexible device configuration through JTAG interface.
- Table 1-1 Shows AG1280 family features

Feature	AG1280
LUTs	1280
Distributed RAM (Kbits)	10
EBR SRAM (Kbits)	68
Maximum User I/O pins	40
Number of PLLs	1
Package	48-Pin QFN

Content

General Description	2
Features	2
Content	3
1. AG1280 Architecture Overview	4
1.1. Functional Description	4
1.2. Logic Array Blocks.....	4
1.3. Logic Element	4
1.4. FlexTrack Interconnect	5
1.5. Global Signals.....	5
1.6. Phase Locked Loops (PLLs).....	6
1.7. Embedded Block RAM.....	7
1.8. I/O Pin	8
2. Device Configuration.....	8
3. Power-On Reset Circuitry	8
4. DC Electrical Characteristics	8
5. Timing Characteristics	10
6. Pin-Outs	10
7. Reference and Ordering Information.....	11
7.1. Software.....	11
7.2. Ordering Information.....	11
8. Recommended Reflow Profile.....	12
9. RoHS Compliant.....	13
10. ESD Precautions.....	13

1. AG1280 Architecture Overview

1.1. Functional Description

The AG1280 devices contain an industrial state-of-the-art two-dimensional row- and column-based architecture to implement custom logic. Column and row interconnects of various speeds provide signal interconnects between logic blocks (LBs) and IOs.

The logic array consists of LBs, with 16 logic slices (LS) in each LB. A slice is a small unit of logic providing efficient implementation of user logic functions. LBs are grouped into rows and columns across the device. The AG1280 devices' density is ranging from 640 to 1280 slices.

The device global clock network consists of up to 8 global clock lines that drive through the entire device. The global clock network can provide clocks for all resources within the device, such as input/output elements (IOEs), slices. The global clock lines can also be used for other high fan-out signals.

Each device I/O pin is fed by an IOE located at the ends of LB rows and columns around the periphery of the device. I/O pins support various single-ended standards. Each IOE contains a bidirectional I/O buffer.

1.2. Logic Array Blocks

Each Logic Block consists of 16 slices, SLICE carry chains, SLICE control signals, a local interconnect, a look-up table (LUT) chain, and register chain connection lines. There are 32 possible unique inputs into an SLICE. Register chain connections transfer the output of one SLICE's register to the adjacent SLICE's register within a block. The AG1280 software places associated logic within an SLICE or adjacent SLICES, allowing the use of local, LUT chain, and register chain connections for performance and area efficiency.

1.3. Logic Element

The smallest unit of logic in AG1280 architecture, the slice, is compact and provides advanced and flexible features with efficient logic utilization. Each slice features:

- Industrial standard four-input look-up table (LUT4), which is a function generator that can implement any combinatorial logic function of four inputs.
- A programmable register
- A carry chain connection
- A register chain connection
- The ability to drive all types of interconnects: local, row, column, register chain, and inter-tile connections
- Support for efficient packing of LUT and register
- Support for register feedback

Figure 1-1 AG1280 Logic SLICE

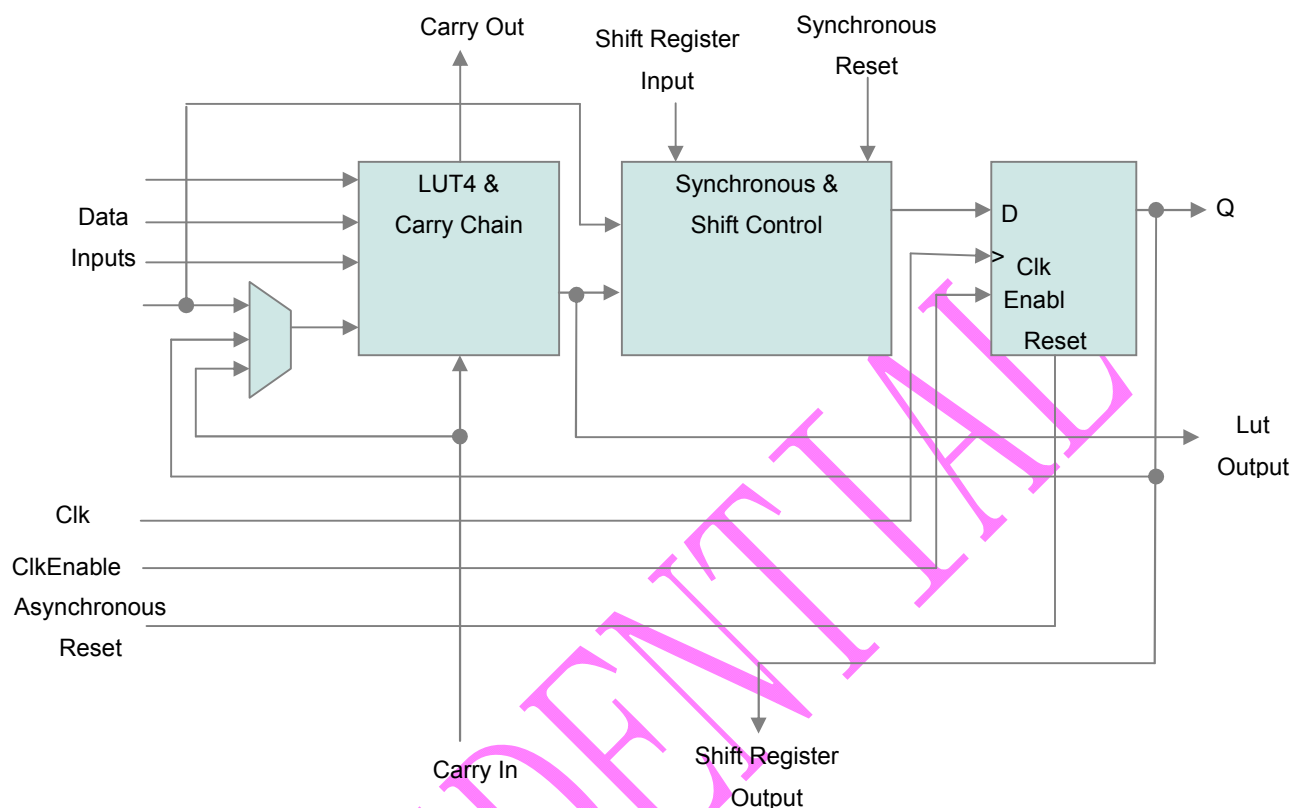

Each slice's register has data, clock, clock enable, and clear inputs. Signals that from global clock network, general-purpose I/O pins, or any internal logic outputs can drive the register's clock and clear control signals. Either general-purpose I/O pins or internal logic can drive the clock enable. For combinational functions, the LUT output bypasses the register and drives directly to the slice outputs resources. The slice is architected so that LUT and register can drive to separate outputs.

1.4. FlexTrack Interconnect

In AG1280 device architecture, FlexTrack interconnect consists of continuous, performance-optimized routing lines used for inter- and intra- design block connectivity. The FlexTrack connects to LEs, and IO pins with row and column connection that span fixed distances.

1.5. Global Signals

Each device has eight dual-purpose dedicated clock pins. The eight global clock lines drive throughout the entire device. The global clock network can provide clocks for all resources within the device including LEs, local interconnect. The global lines can be used for global signals distribution.

1.6. Phase Locked Loops (PLLs)

The AG1280 provides PLL support. The PLL has four output. The source of the PLL input divider can come from an external pin or from internal routing. There are four sources of feedback signals to the feedback divider: from CLKINTFB (internal feedback port), from the global clock nets, from the output of the post scalar divider, and from the routing (or from an external pin). There is a PLL_LOCK signal to indicate that the PLL has locked on to the input clock signal. Figure 1-2 shows the PLL diagram.

The setup and hold times of the device can be improved by programming a delay in the feedback or input path of the PLL which will advance or delay the output clock with reference to the input clock. This delay can be either programmed during configuration or can be adjusted dynamically. In dynamic mode, the PLL may lose lock after adjustment and not relock until the tLOCK parameter has been satisfied. Additionally, the phase and duty cycle block allows the user to adjust the phase and duty cycle of the CLKOS output.

The PLLs provide the ability to synthesize clock frequencies. Each PLL has four dividers associated with it: input clock divider, feedback divider, post scalar divider, and secondary clock divider. The input clock divider is used to divide the input clock signal, while the feedback divider is used to multiply the input clock signal. The post scalar divider allows the VCO to operate at higher frequencies than the clock output, thereby increasing the frequency range. The secondary divider is used to derive lower frequency outputs.

Figure 1-2. PLL Diagram

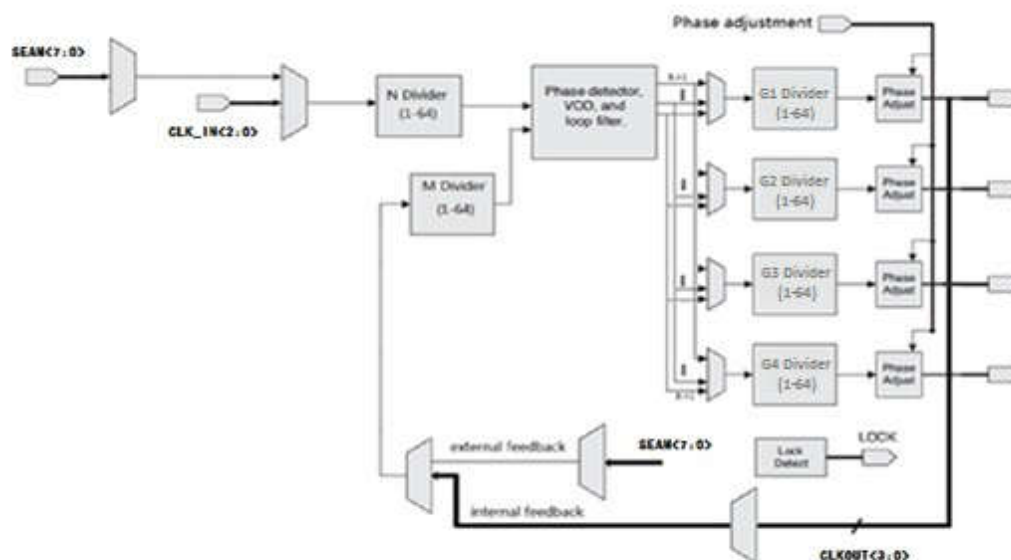

PLL Output Features:

- Output frequency is 16MHz-275MHz.
- VCO range 533MHz – 1066MHz
- Jitter is about 5%.
- Static current <1uA

- Operating Temperature Range:- 25°C ~ 125°C
- Operation Voltage: 1.2V ± 5%

PLL Input Features:

- 10MHz-133MHz.
- Power down PLL.
- A reset input.

1.7.Embedded Block RAM

AG1280 contains 14 Embedded Block RAMs (EBRs). The EBR consists of a 4.5Kbit RAM, with dedicated input and output registers. This memory can be used for a wide variety of purposes including data buffering and FIFO. The EBR block can implement single port, dual port, simple dual port, or FIFO memories. Each block can be used in a variety of depths and widths as shown in Table 1-1.

Memory Mode	Configurations
Single Port	4096 x 1 2048 x 2 1024 x 4 512 x 9 256 x 18 128 x 36
True Dual Port	4096 x 1 2048 x 2 1024 x 4 512 x 9 256 x 18
Pseudo Dual Port	4096 x 1 2048 x 2 1024 x 4 512 x 9 256 x 18 128 x 36
FIFO	4096 x 1 2048 x 2 1024 x 4 512 x 9 256 x 18 128 x 36

If desired, the contents of the RAM can be pre-loaded during device configuration.

By preloading the RAM block during the chip configuration cycle and disabling the write controls, the EBR block can also be utilized as a ROM.

Larger and deeper blocks of RAM can be created using EBR Blocks.

In all the RAM modes, the input data and addresses for the ports are registered at the input of the memory array. The output data of the memory is optionally registered at the memory array output.

The EBR memory supports three forms of write behavior for single or dual port operation:

1. Normal: Data on the output appears only during the read cycle.
2. Write Through: A copy of the input data appears at the output of the same port.
3. Read-Before-Write: When new data is being written, the old data of the address appears at the output.

1.8. I/O Pin

I/O supported features:

- Supports 3.3-V, 2.5-V, 1.8-V, and 1.5-V logic levels
- Programmable drive strength, bus-hold, pull-up resistors, open-drain output, and Schmitt triggers input.
- 3.3-V, 2.5-V, 1.8-V, 1.5-V LVCMOS and LVTTL standards

2. Device Configuration

AG1280 device supports JTAG mode configuration. Internal Flash provides a non-volatile storage for the configuration data.

3. Power-On Reset Circuitry

When power is applied to AG1280 devices, the POR circuit monitors V_{CC} and begins SRAM download at an approximate voltage of 1.2V AG1280 devices.

Entry into user mode is gated by whether V_{CCIO} bank2 are powered with sufficient operating voltage. If V_{CC} and V_{CCIO} are powered simultaneously, the device enters user mode.

For AG1280 when in user mode, the POR circuitry continues to monitor the V_{CC} (but not V_{CCIO}) voltage level to detect a brown-out condition. If there is a V_{CC} voltage sag at during user mode, the POR circuit resets the SRAM and tri-states the I/O pins. Once V_{CC} rises back to approximately 1.2V, the SRAM download restarts and the device begins to operate.

4. DC Electrical Characteristics

Table 4-1 Recommended Operating Conditions

Symbol	Parameter	Min.	Max.	Units	
VCC	Core Supply Voltage	1.14	1.26	V	
VCCPLL	PLL Supply Voltage	1.14	1.26	V	
VCCIO	I/O Driver Supply	VCCIO0,2	1.71	3.46	V

	Voltage	VCC_SPI	1.71	3.46	V
--	---------	---------	------	------	---

Table 4-2 Recommended Operating Conditions

Symbol	Parameter	Typ.	Units
IIL, IIH	Input or I/O Leakage	+/-1	μA
C1	I/O Capacitance	6	pF
C2	Global Input Buffer Capacitance	6	pF
VHYST	Input Hysteresis	200	mV
IPU	Internal PIO Pull-up Current	-35 (VCCIO = 1.8V)	μA
		-49 (VCCIO = 2.5V)	μA
		-65 (VCCIO = 3.3V)	μA
ICC	Core Power Supply	50	μA
ICCPLL	PLL Power Supply	1	μA

Table 4-3 Peak Startup Supply Current

Symbol	Parameter	Max.	Units
ICCPEAK	Core Power Supply	6.5	mA
ICCPLLPEAK	PLL Power Supply	1.5	mA
ICCIOPEAK, ICC_SPIPEAK	Bank Power Supply	3.4	mA

Table 4-4 IO Single-Ended DC Electrical Characteristics

Input/ Output Standard	VIL		VIH		VOL Max. (V)	VOH Min. (V)	IOL Max. (mA)	IOH Max. (mA)
	Min. (V)	Max. (V)	Min. (V)	Max. (V)				
LVC MOS 3.3	-0.3	0.8	2.0	VCCIO +0.2V	0.4	VCCIO -0.5	8,16,24	-8,-16,-24
LVC MOS 2.5	-0.3	0.7	1.7	VCCIO +0.2V	0.4	VCCIO -0.5	6,12,18	-6,-12,-18
LVC MOS 1.8	-0.3	0.35 VCCIO	0.65 VCCIO	VCCIO +0.2V	0.4	VCCIO -0.4	4, 8,12	-4, -8,-12

Table 4-5 Power-On-Reset Voltage Levels

Symbol	Parameter		Min.	Max	Units
VPORUP	Power-On-Reset ramp-up trip point (band gap based circuit monitoring VCC, VCCIO_2, VCC_SPI)	VCC	0.55	0.8	V
		VCCIO_2	0.9	1.1	V
		VCC_SPI	0.9	1.1	V

5. Timing Characteristics

Table 5-1 Typical Building Block Function Performance

Register-to-Register Performance		
Function	Timing	Units
16-bit counter	250	MHz
64-bit counter	100	MHz

Table 5-2 External Switching Characteristics

Parameter	Description	Min.	Max.	Units
Global Clocks				
f _{MAX_GBUF}	Frequency for Global Buffer Clock network	-	300	MHz
f _{MAX_GBUF}	Frequency for Global Buffer Clock network	-	200	ps
Pin-LUT-Pin Propagation Delay				
t _{PD}	Best case propagation delay through one LUT-4	-	6.5	ns
General I/O Pin Parameters (Using Global Buffer Clock without PLL)				
t _{CO}	Clock to Output - PIO Output Register	-	6.5	ns
t _{SU}	Clock to Data Setup - PIO Input Register	-0.3	-	ns
t _H	Clock to Data Hold - PIO Input Register	1.9	-	ns

Table 5-3 Maximum sysIO Buffer Performance

I/O Standard	Max. Speed	Units
Inputs		
LVC MOS33	250	MHz
LVC MOS25	250	MHz
LVC MOS18	250	MHz
Outputs		
LVC MOS33	250	MHz
LVC MOS25	250	MHz
LVC MOS18	155	MHz

6. Pin-Outs

Refer to Pin-Outs printouts for AG1280 device family.

7. Reference and Ordering Information

7.1. Software

AG1280 Software tools support from RTL to bit stream configuration implementation and programming. Supported operating system platforms include Microsoft Windows and Linux.

7.2. Ordering Information

Table 7-1 Device Part Number Description

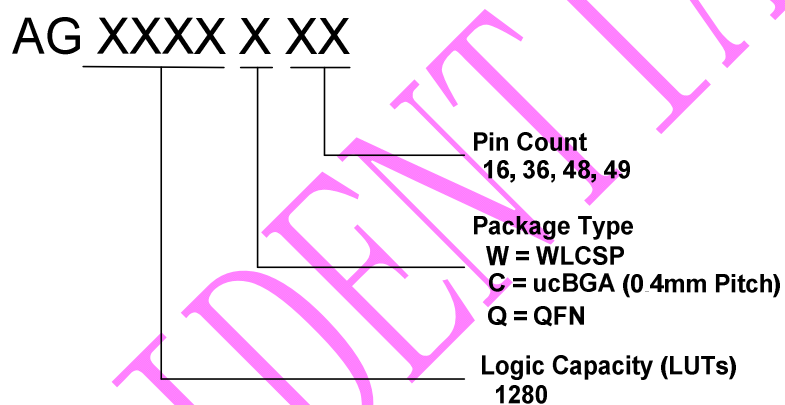

Package Thickness	Volume mm3	Volume mm3
	<350	≥350
<2.5mm	240 + 0/-5 °C	225 + 0/-5 °C
≥2.5mm	225 + 0/-5 °C	225 + 0/-5 °C

Table 8-3 Pb-free Process – Package Classification Reflow Temperatures

Package Thickness	Volume mm3 <350	Volume mm3 350-2000	Volume mm3 >2000
<1.6mm	260 + 0 °C *	260 + 0 °C *	260 + 0 °C *
1.6mm – 2.5mm	260 + 0 °C *	250 + 0 °C *	245 + 0 °C *
≥2.5mm	250 + 0 °C *	245 + 0 °C *	245 + 0 °C *

*Tolerance : The device manufacturer/supplier shall assure process compatibility up to and including the stated classification temperature(this mean Peak reflow temperature + 0 °C. For example 260+ 0 °C) at the rated MSL Level.

Note 1: All temperature refer topside of the package. Measured on the package body surface.

Note 2: The profiling tolerance is + 0 °C, - X °C (based on machine variation capability)whatever is required to control the profile process but at no time will it exceed – 5 °C. The producer assures process compatibility at the peak reflow profile temperatures defined in Table 9-3.

Note 3: Package volume excludes external terminals(balls, bumps, lands, leads) and/or non integral heat sinks.

Note 4: The maximum component temperature reached during reflow depends on package the thickness and volume. The use of convection reflow processes reduces the thermal gradients between packages. However, thermal gradients due to differences in thermal mass of SMD package may sill exist.

Note 5: Components intended for use in a “lead-free” assembly process shall be evaluated using the “lead free” classification temperatures and profiles defined in Table8-1, 8-2, 8-3 whether or not lead free.

9. RoHS Compliant

The product does not contain lead, mercury, cadmium, hexavalent chromium, polybrominated biphenyls (PBB) or polybrominated diphenyl ethers (PBDE), and are therefore considered RoHS compliant.

10. ESD Precautions

ESD protection circuitry is contended in this device, but special handling precautions are required.

11. Package Diagram(QFN 48)

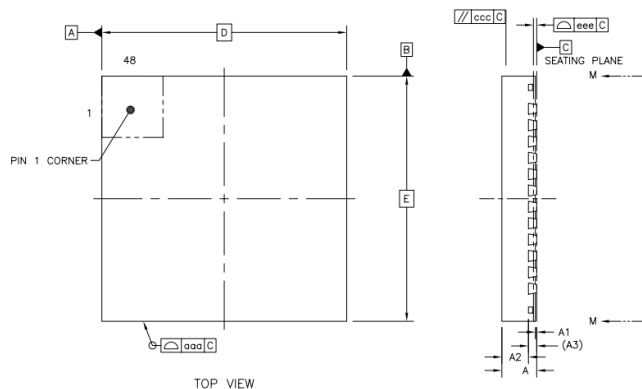

DESCRIPTION	SYMBOL	MILLIMETER		
		MIN	NOM	MAX
TOTAL THICKNESS	A	0.8	0.85	0.9
STAND OFF	A1	0	0.035	0.05
MOLD THICKNESS	A2	---	0.65	0.67
L/F THICKNESS	A3	0.203 REF		
LEAD WIDTH	b	0.15	0.20	0.25
BODY SIZE	X	D	5.90	6.00
	Y	E	5.90	6.00
LEAD PITCH	e	0.40 BSC		
EP SIZE	X	D2	3.70	3.80
	Y	E2	3.70	3.80
LEAD LENGTH	L	0.30	0.40	0.50
PACKAGE EDGE TOLERANCE	aaa	0.1		
LEAD OFFSET	bbb	0.07		
MOLD FLATNESS	ccc	0.1		
	ddd	0.05		
COPLANARITY	eee	0.08		
EXPOSED PAD OFFSET	fff	0.1		

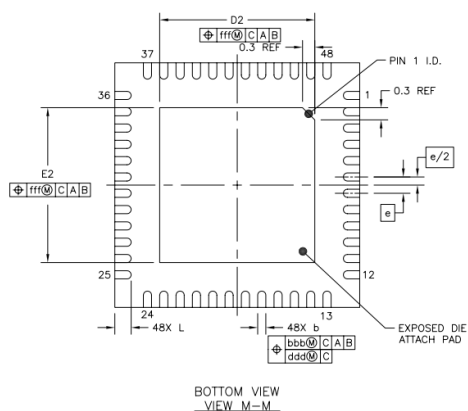

CONFIDENTIAL